

INSTALLATION MANUAL

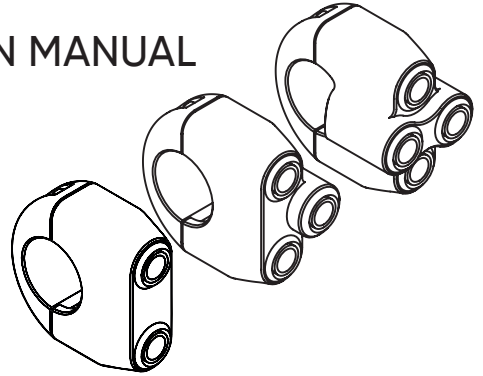

Disclaimer

Rebelmoto accepts no liability for damage, injury or any legal responsibility incurred directly or indirectly from the use or installation of this product. The use and installation of this product is at user's own risk.

Important!

Make sure to disconnect the battery before installation, failure to do so may result in injury or damage to the product or other parts of your motorcycle.

The switch buttons in the rebel switch are rated at 1A and are designed to be used together with a control box. If you wish to connect the rebel switch directly to something that draws more than 1A current, you have to use a relay.

When soldering be careful not to overheat the terminals as this can damage the push button.

Installation

STEP 1

Remove the push buttons. Measure out the desired length of wire and solder it to the push buttons. We recommend 0.22mm² (24 AWG) wire. Each push button has four terminals (two on the none LED version). The two terminals closest to the center where there is a + and - symbol next to it, are the positive and negative terminals for the LED light. The two outer terminals are for the switching function. Due to the compact design there is little space between the terminals, it is therefore necessary to use shrink tubing over the terminals once the wiring has been soldered on. This is to ensure not to create a short circuit when mounted on the handlebars. When soldering be careful not to overheat the terminals as this can damage the push button.

STEP 2

Put a piece of masking tape on the handlebars where you wish to install the rebel switch. Mount the rebel switch housing, without the push buttons, on the handlebars on the taped area where you want the switch installed. Be careful not to over tighten the 3mm bolts. With a pen mark the tape through the 2-4 holes in the housing, depending on whether you are installing the 2, 3 or 4 button rebel switch. Unmount the rebel switch housing and drill 6mm holes in the handlebars. On the 2 button rebel switch, 1-2 holes are sufficient. For the 3 & 4 button rebel switch, 2-3 holes are sufficient on most bars to get all the wires through.

STEP 3

Screw the push buttons into the rebel switch housing. Apply some Loctite thread sealant if you wish an extra secure fit. Do not use any tools when screwing in the push buttons as this may scratch the buttons or the housing. Pull the wiring through the handlebars and mount the rebel switch.